

# XTOP

Brøndby, June 25th. 2008

## Standard Specifications:

- The XTOP is made from exclusively extruded aluminium profiles (silver anodized)
- The base structure is made from galvanized steel.
- All the outside weatherstrips are exclusively made silicone profiles.
- The XTOP has a load capacity of 100 Kg.
- Both the XTOP and the original tailgate can be opened/locked individually.
- XTOP has 2 gas driven absorbers for easy opening and closing.
- All mounting brackets, bolts and washers are included.
- All bearings/bolts are selected to withstand Heavy Duty operation.
- Quick Install time : 2 - 3 Hours.

## Standard Price:

<u>Nissan DC</u>	<u>1850.00</u>	<u>€+VAT</u>
<u>Nissan KC</u>	<u>1900.00</u>	<u>€+VAT</u>



Prices are final customer prices, -Wholesale inquiries are welcome.  
Freight and packeting varies from destination.

## Extra options:



- Front storage box (in addition with XTOP) 415.00 €+VAT



- Front storage box ONLY (without XTOP) 605.00 €+VAT

-If ordered without XTOP the front storage box can later on be combined with XTOP components..



**Rearview of XTOP**



**Sideview of XTOP w. standard front**



**Optional lockable front storage box**



**Storage box combined with XTOP**



**XTOP allows easy access for loading / unloading cargo**



**Sturdy construction allows XTOP to be used even as a work-platform**



**Exclusively produced aluminum profiles are used for XTOP Notice the 'top rail' for securing cargo.**



**-Notice the flush roof & XTOP**

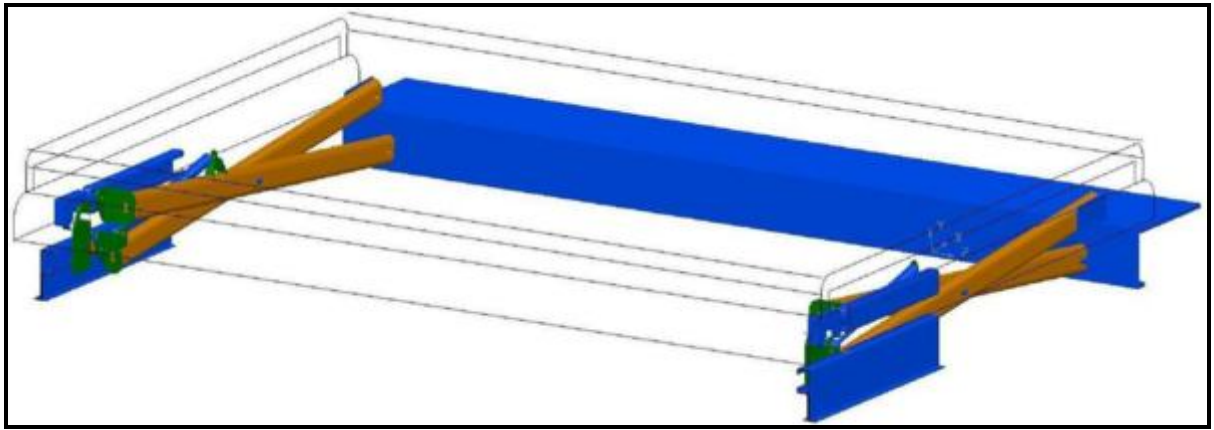

**Exploded view of retracted XTOP –Notice that only a minimum of space is used**

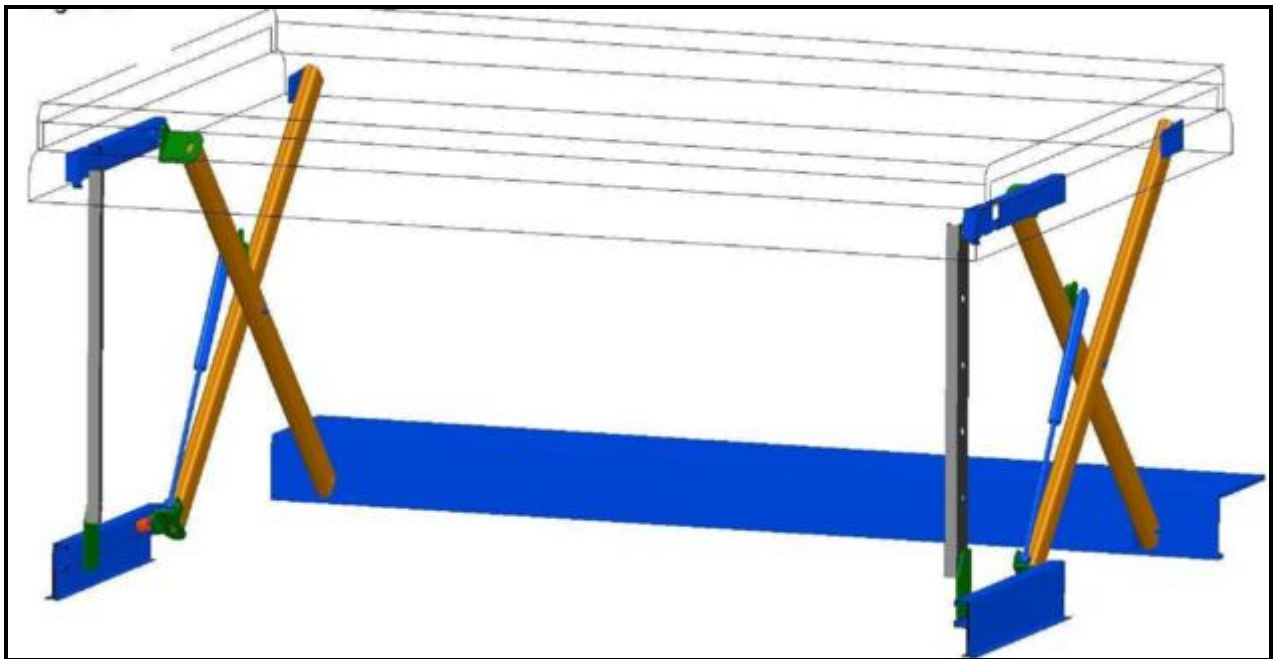

**Exploded view of extracted XTOP –Here shown with safetybar in highest position**

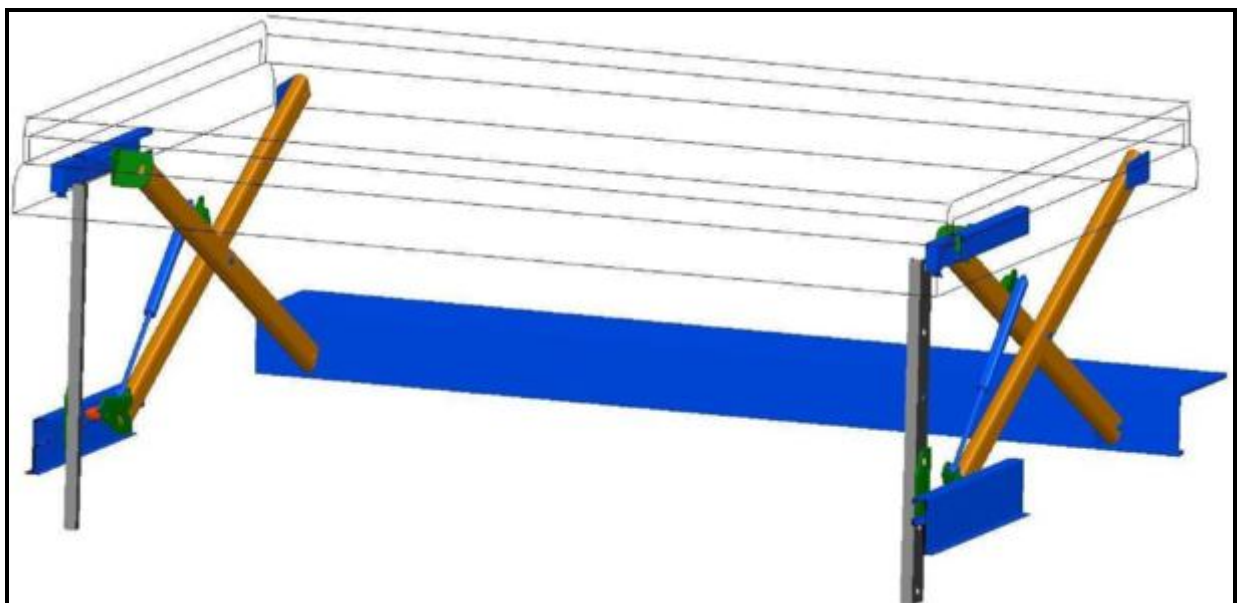

**Safetybar installed in a lower position –allowing XTOP to carry taller loads on top**



**All materials are carefully selected to withstand heavy-duty operation**



**6 different positions allows to carry loads with various heights**



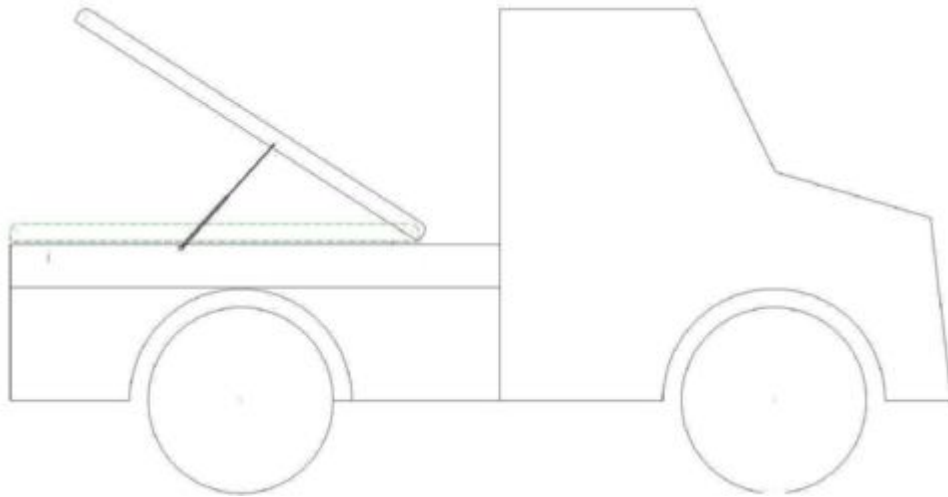

**Traditionally tonneau covers / tops have limited access and storage capabilities**

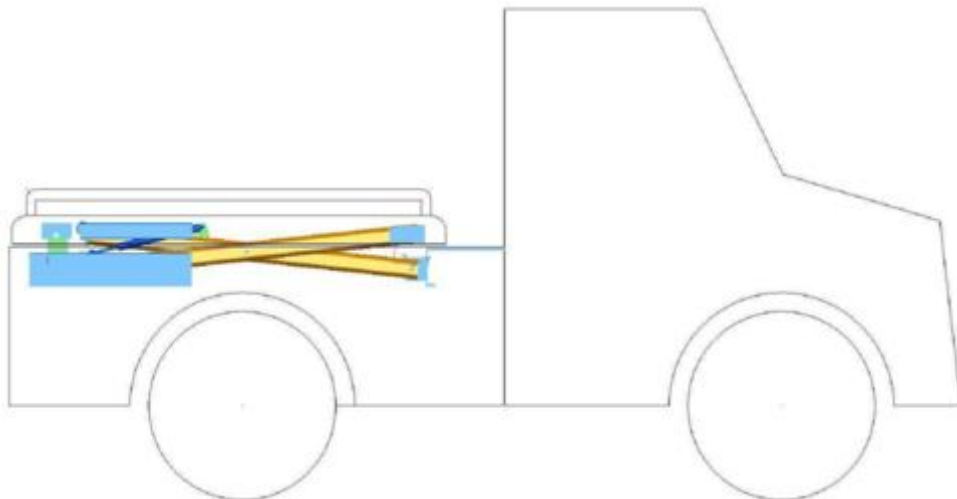

**XTOP let's you carry loads both under and on the roof**

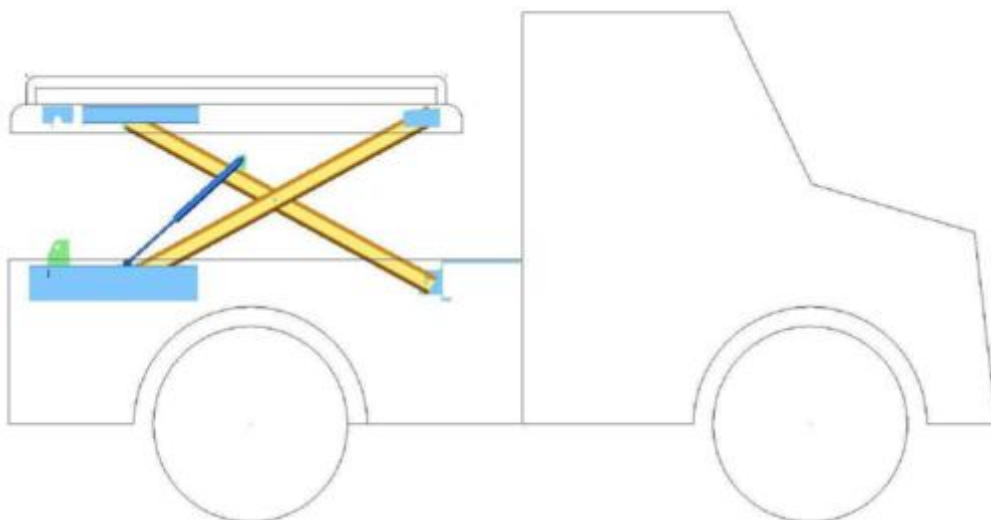

**XTOP opens up vertically and therefore has easy access**

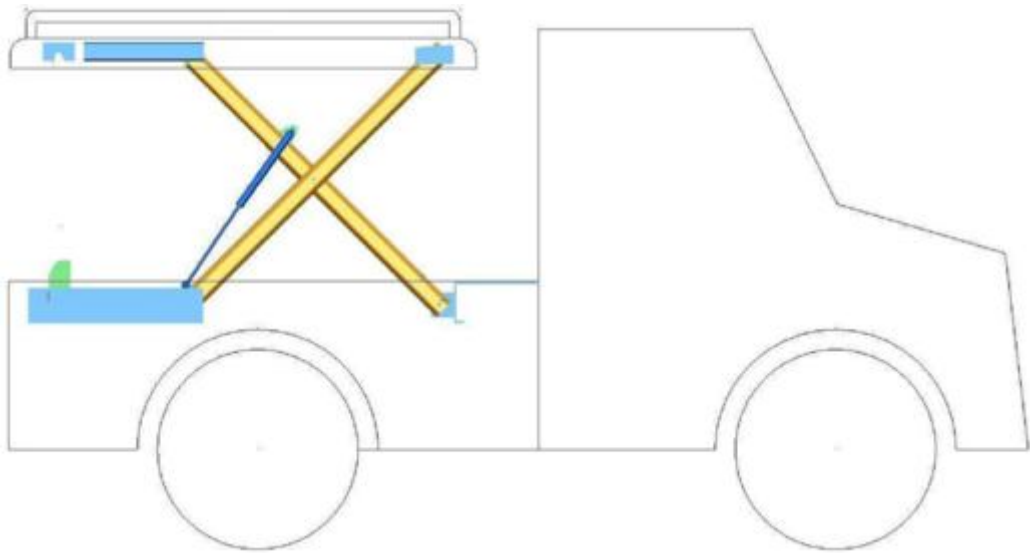

**XTOP is flush with the roofline**

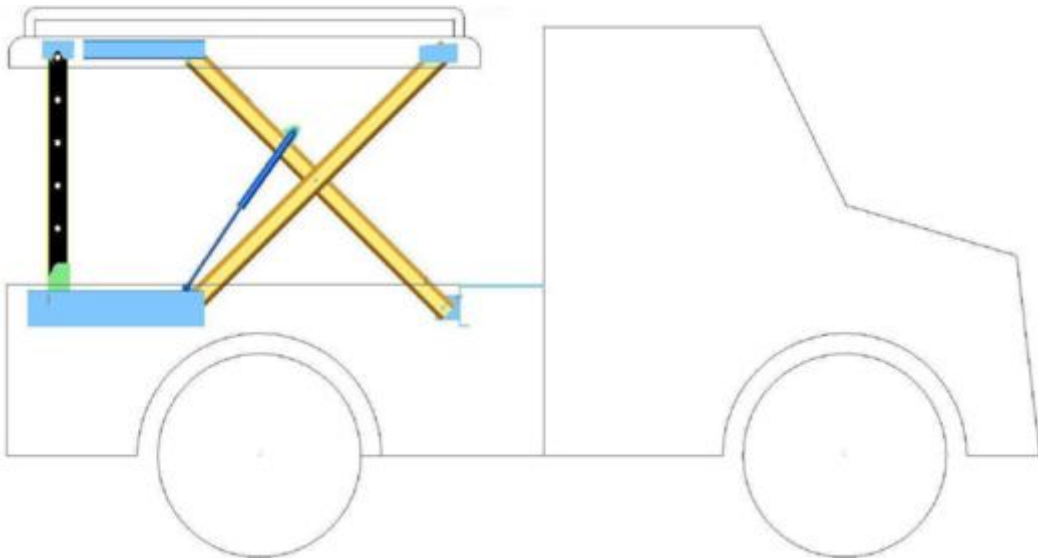

**With the adjustable rear safetybar you can carry loads in 5 additional heights**

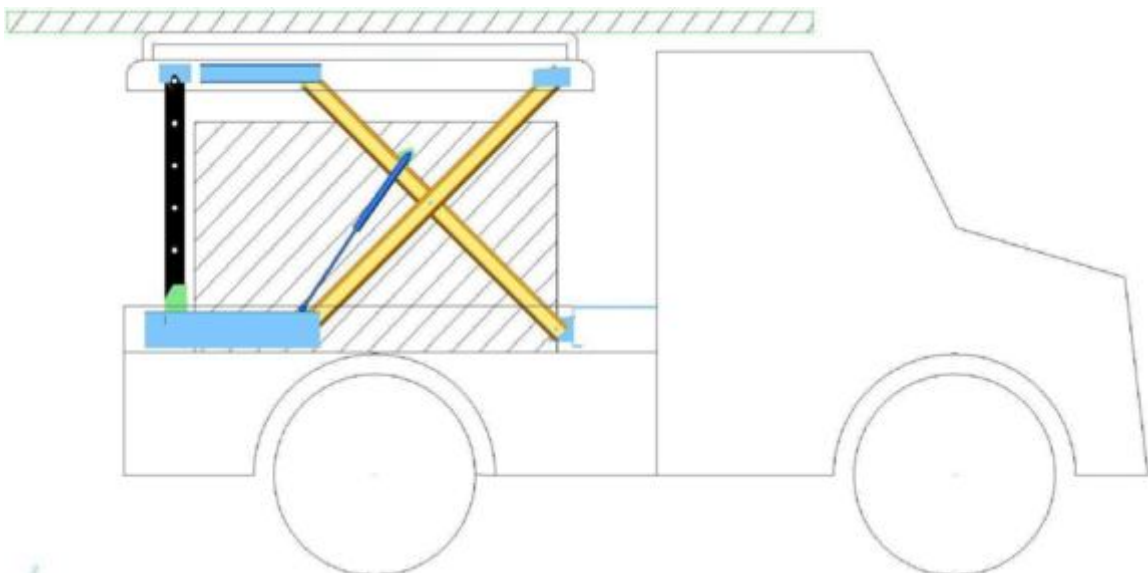

**Shown here (in highest position) is cargo both on top and below XTOP**



We feel that both quality, design and functionality is unsurpassed and are proud to offer the XTOP starting late summer 2008

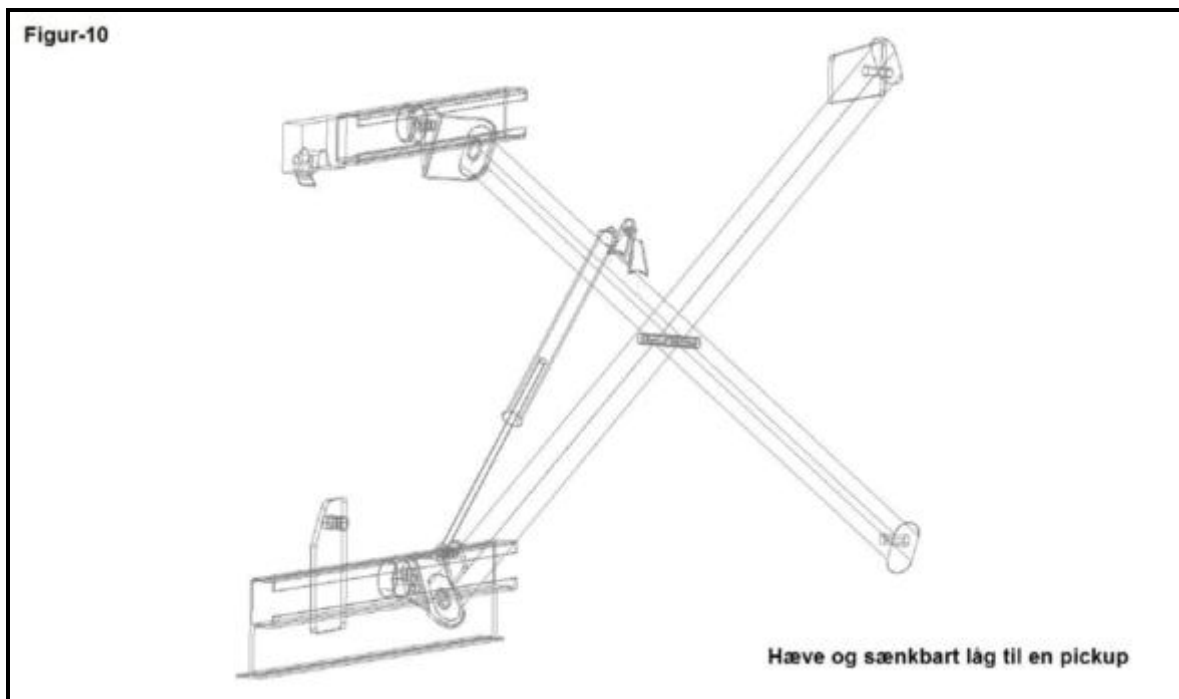

**XTOP**

and all of it's components are Pat. Pending & Reg. Design.

